

Wood Joints Multiple Choice Questions

Write the correct answers in the boxes.

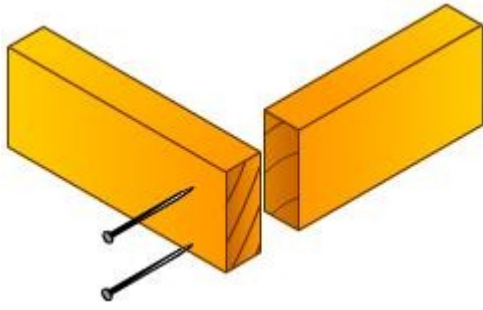

This is a:

- Comb joint
- Butt joint
- Cross halving joint
- Lapped joint

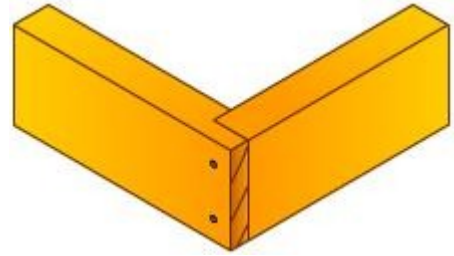

This is a:

- Rebated joint
- Butt joint
- T-bridle joint
- Lapped joint

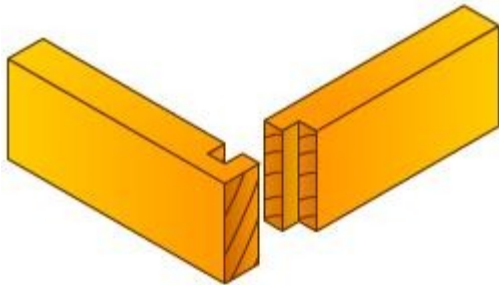

This is a:

- Rebated joint
- Tongue and groove joint
- Housing joint
- Dovetail joint

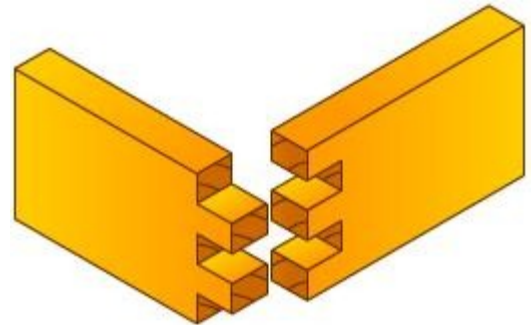

This is a:

- Finger joint
- Dovetail joint
- Comb joint
- Lapped joint

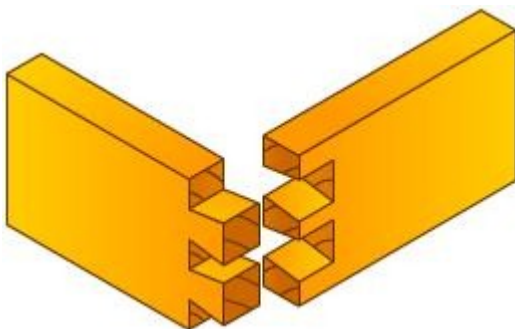

This is a:

- Comb joint
- Corner bridle joint
- Dowelled joint
- Dovetail joint

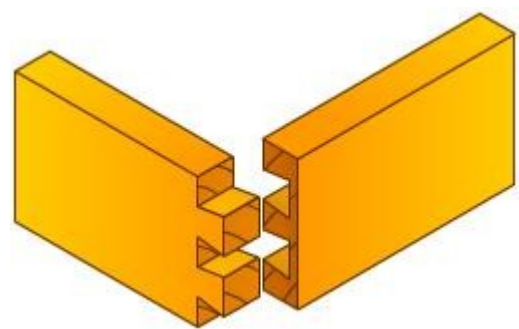

This is a:

- Lapped dovetail joint
- Bare faced tenon
- Corner bridle joint
- Butt joint

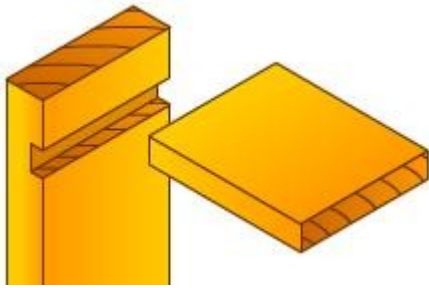

This is a:

- Stopped mortice and tenon joint
- Through mortice and tenon joint
- Housing joint
- Rebated joint

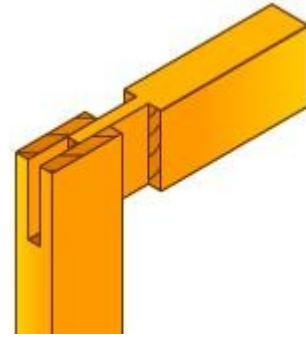

This is a:

- Corner bridle joint
- Tee bridle joint
- Tee halving joint
- Lapped joint

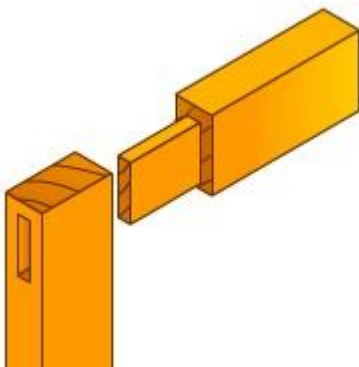

This is a:

- Tee halving joint
- Stopped mortice and tenon joint
- Through mortice and tenon joint
- Dowelled joint

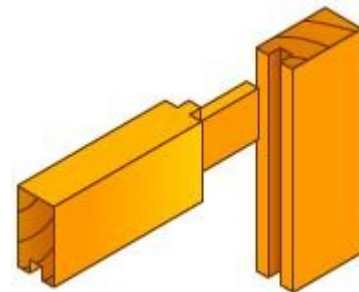

This is a:

- Tongue and groove joint
- Haunched mortice and tenon joint
- Stopped mortice and tenon joint
- Dowelled joint

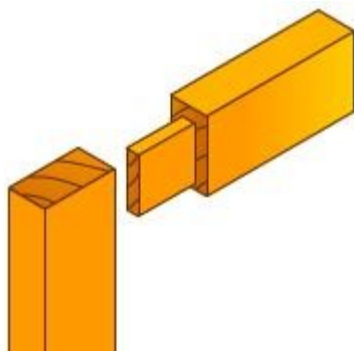

This is a:

- Stopped mortice and tenon joint
- Tongue and groove joint
- Corner bridle joint
- Tee bridle joint

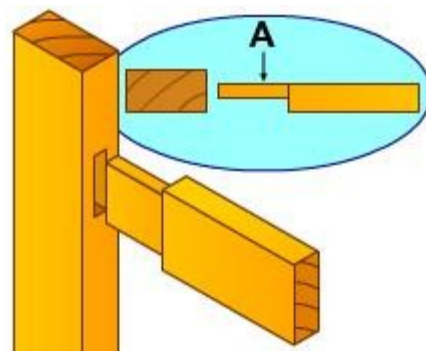

Part "A" is called a:

- Rebate
- Lapped joint
- Tee bridle joint
- Bare faced tenon

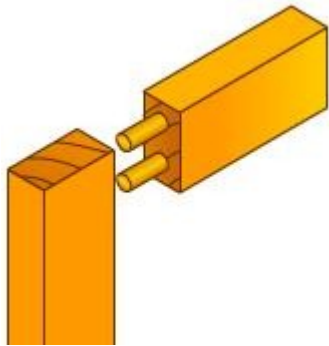

This is a:

- Dowelled joint
- Comb joint
- Tee halving joint
- Dovetail joint

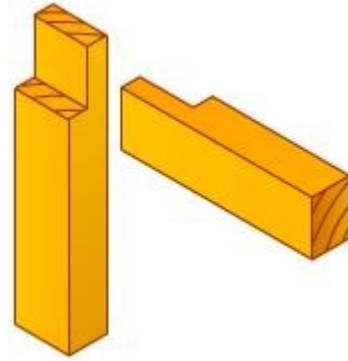

This is a:

- Tee bridle joint
- Dovetail halving joint
- Tee halving joint
- Corner halving joint

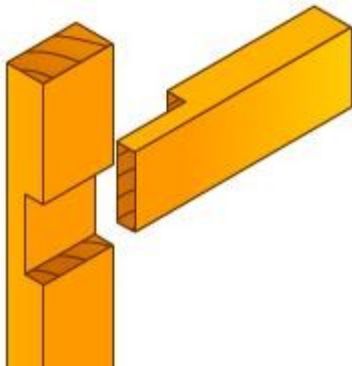

This is a:

- Lapped joint
- Tee bridle joint
- Dovetail joint
- Tee halving joint

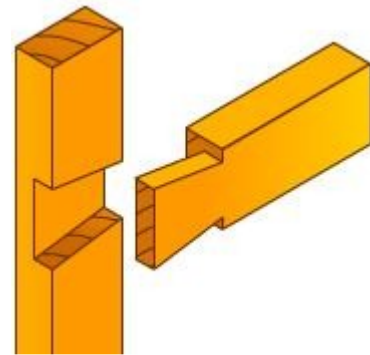

This is a:

- T-bridle joint
- Dovetail halving joint
- T-halving joint
- Corner bridle joint

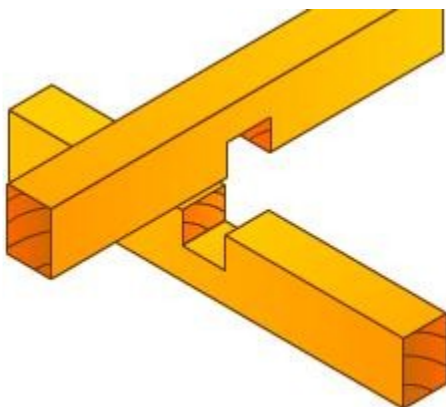

This is a:

- Cross halving joint
- Lapped joint
- Stopped mortice and tenon joint
- Housing joint

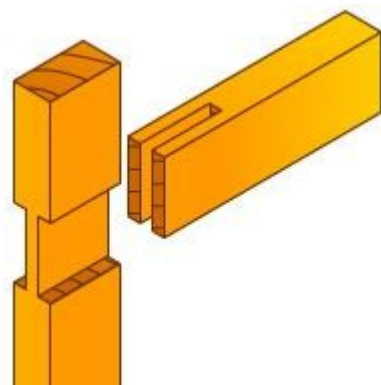

This is a:

- T-halving joint
- Cross halving joint
- T-bridle joint
- Lapped dovetail joint

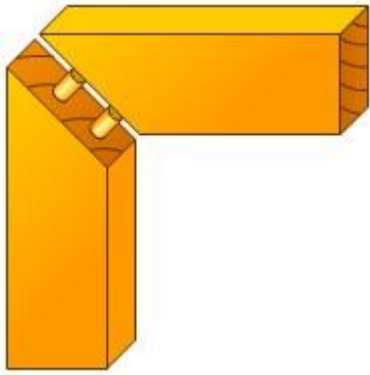

This is a:

- Dowelled mitre joint
- Biscuit reinforced mitre joint
- Bare faced tenon
- Lapped joint

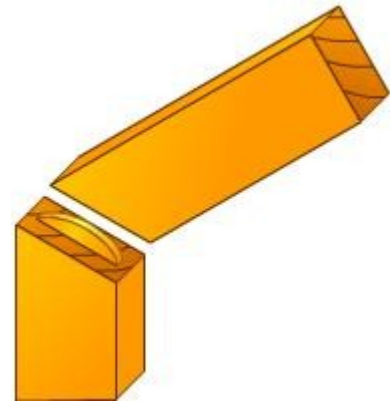

This is a:

- Cross halving joint
- Dowelled joint
- Dowelled mitre joint
- Biscuit reinforced mitre joint

Write your name:

Wood Joints

Write the correct name of each joint in the boxes provided.

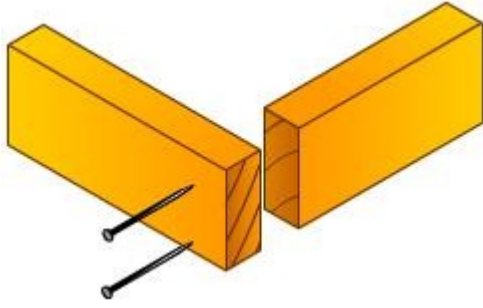

This is a:

- Comb joint
- Butt joint
- Cross halving joint
- Lapped joint

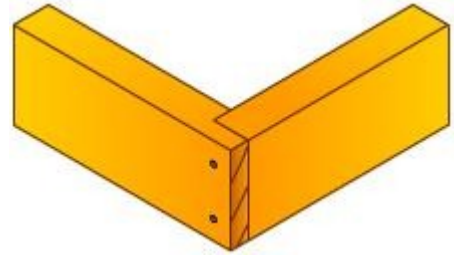

This is a:

- Rebated joint
- Butt joint
- T-bridle joint
- Lapped joint

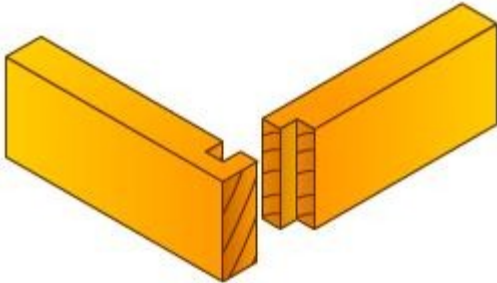

This is a:

- Rebated joint
- Tongue and groove joint
- Housing joint
- Dovetail joint

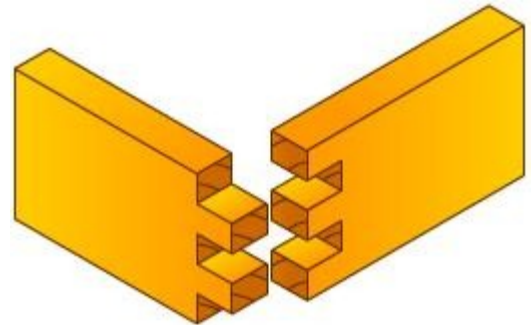

This is a:

- Finger joint
- Dovetail joint
- Comb joint
- Lapped joint

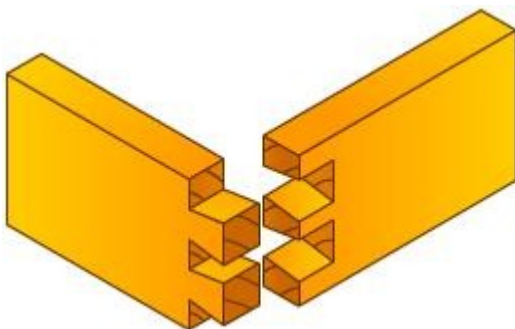

This is a:

- Comb joint
- Corner bridle joint
- Dowelled joint
- Dovetail joint

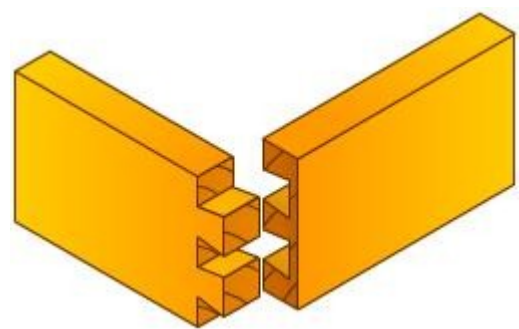

This is a:

- Lapped dovetail joint
- Bare faced tenon
- Corner bridle joint
- Butt joint

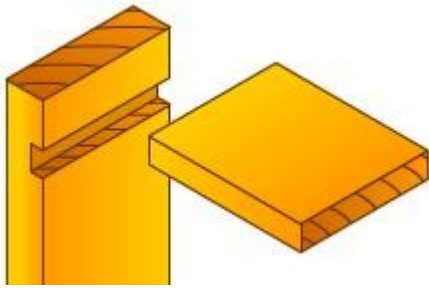

This is a:

- Stopped mortice and tenon joint
- Through mortice and tenon joint
- Housing joint
- Rebated joint

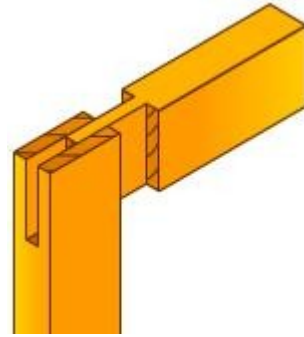

This is a:

- Corner bridle joint
- Tee bridle joint
- Tee halving joint
- Lapped joint

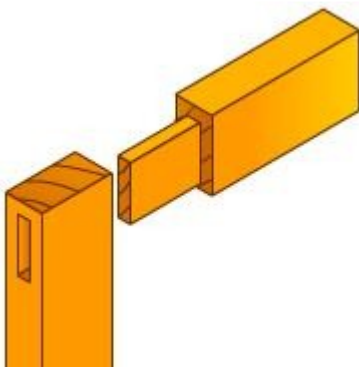

This is a:

- Tee halving joint
- Stopped mortice and tenon joint
- Through mortice and tenon joint
- Dowelled joint

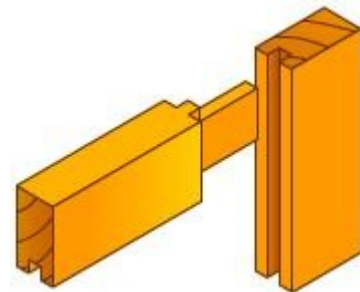

This is a:

- Tongue and groove joint
- Haunched mortice and tenon joint
- Stopped mortice and tenon joint
- Dowelled joint

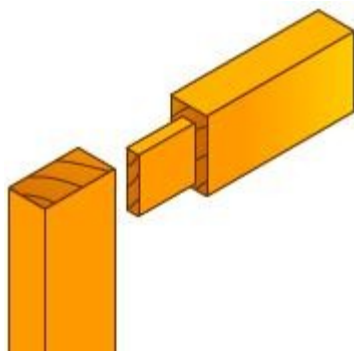

This is a:

- Stopped mortice and tenon joint
- Tongue and groove joint
- Corner bridle joint
- Tee bridle joint

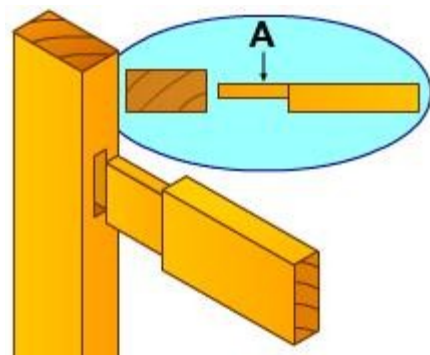

Part "A" is called a:

- Rebate
- Lapped joint
- Tee bridle joint
- Bare faced tenon

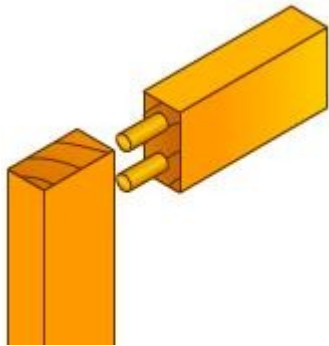

This is a:

- Dowelled joint
- Comb joint
- Tee halving joint
- Dovetail joint

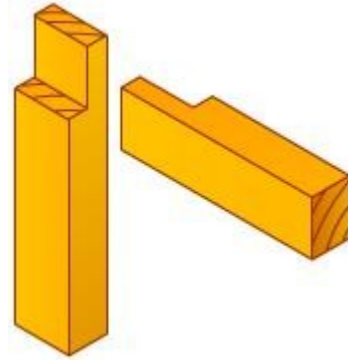

This is a:

- Tee bridle joint
- Dovetail halving joint
- Tee halving joint
- Corner halving joint

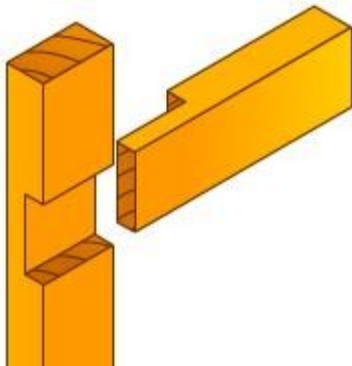

This is a:

- Lapped joint
- Tee bridle joint
- Dovetail joint
- Tee halving joint

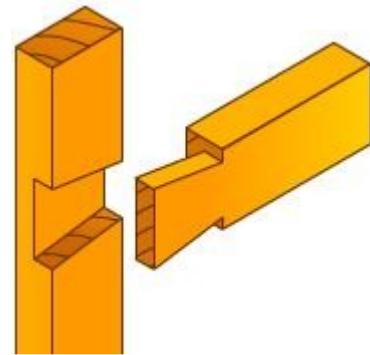

This is a:

- T-bridle joint
- Dovetail halving joint
- T-halving joint
- Corner bridle joint

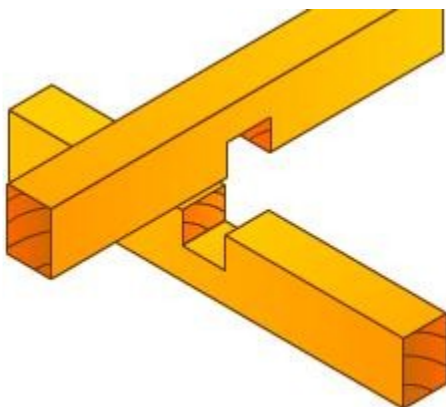

This is a:

- Cross halving joint
- Lapped joint
- Stopped mortice and tenon joint
- Housing joint

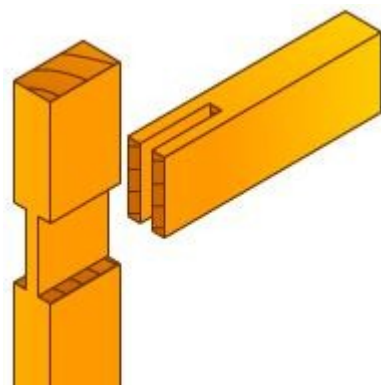

This is a:

- T-halving joint
- Cross halving joint
- T-bridle joint
- Lapped dovetail joint

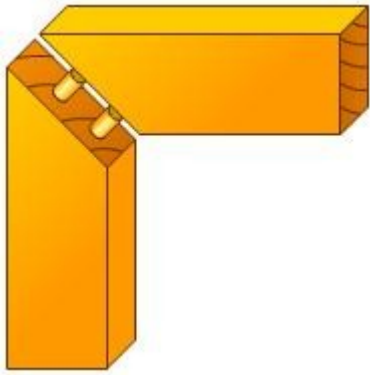

This is a:

- Dowelled mitre joint
- Biscuit reinforced mitre joint
- Bare faced tenon
- Lapped joint

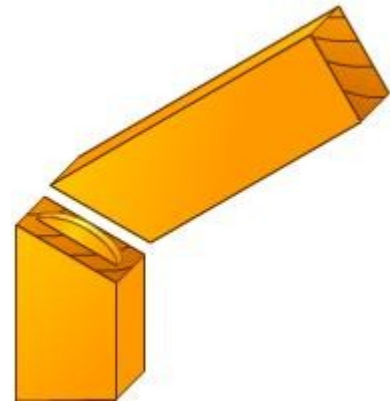

This is a:

- Cross halving joint
- Dowelled joint
- Dowelled mitre joint
- Biscuit reinforced mitre joint

Write your name: