

# Screws

## Introduction

Screws are used for two purposes:

1. To clamp things together.
2. To control motion.

### 1. Nuts, bolts and screws used to clamp things together.

Nuts, bolts and screws that are used for clamping have screw threads.

An **external screw thread** is a helical groove that has been cut around a shaft. A shaft with a thread cut into it is called a screw. A screw with a parallel shank and a hexagonal head is called a bolt. A screw with any other shaped head, such as a pan head, cheese head or a countersunk head is simply called a screw, e.g. a countersunk head screw.

An **internal screw thread** is a helical groove that has been cut into a cylindrical hole. An internal screw thread may be cut into any product part or it may be cut into a hole in a short length of hexagonal bar. When the internal screw thread is cut into a short length of hexagonal bar, the part is called a nut.

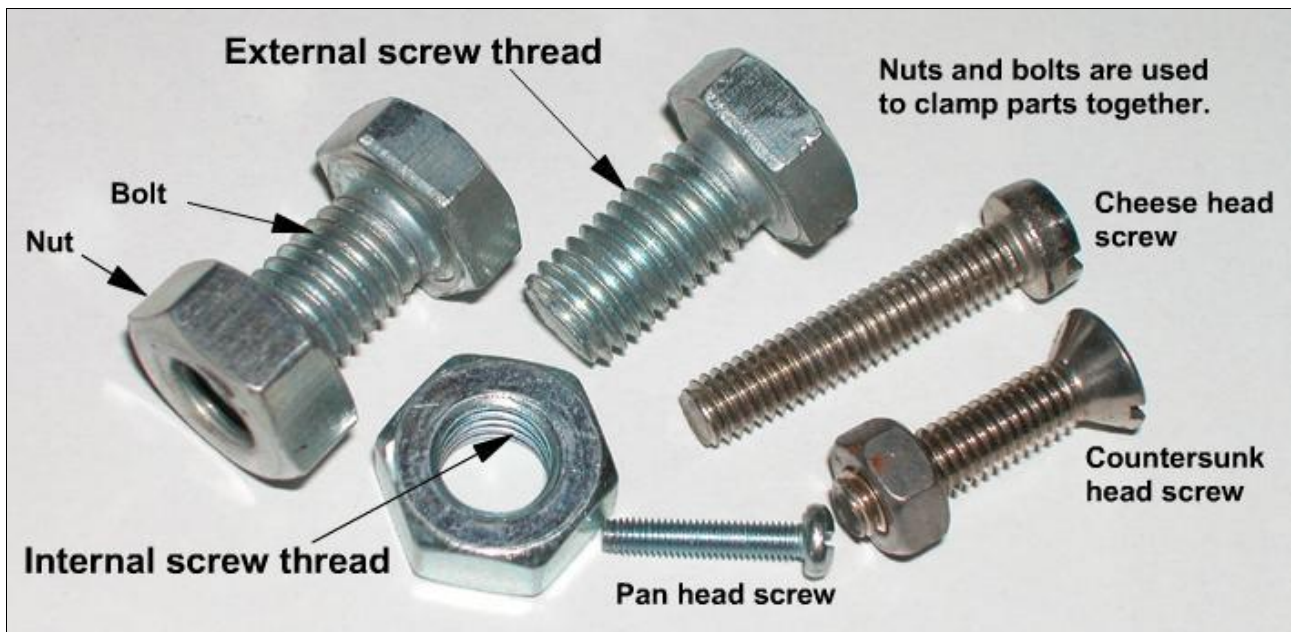

There are standard sizes for screw heads and for nuts. The sizes vary slightly according to the standard used, but they are similar. The most commonly used standard in Europe is the ISO Metric screw thread, defined in ISO 68-1.

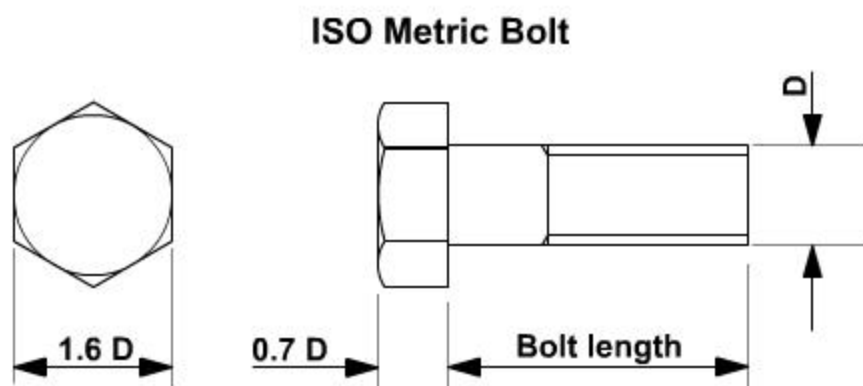

## ISO Metric Nuts and Washers

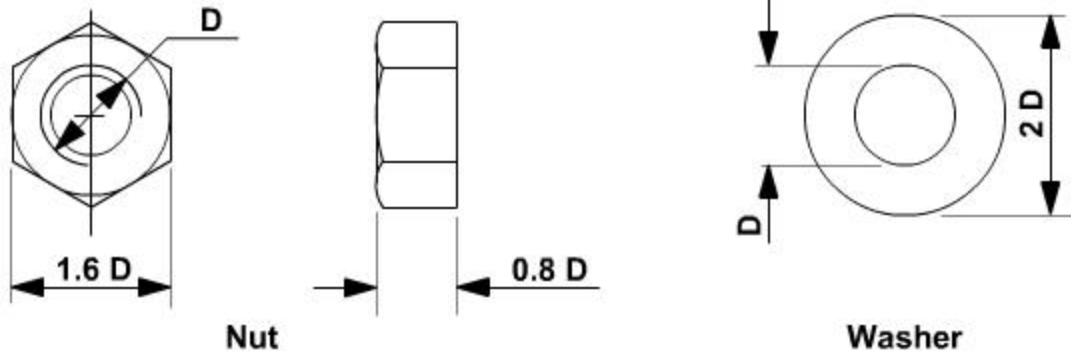

## Countersunk head socket screw

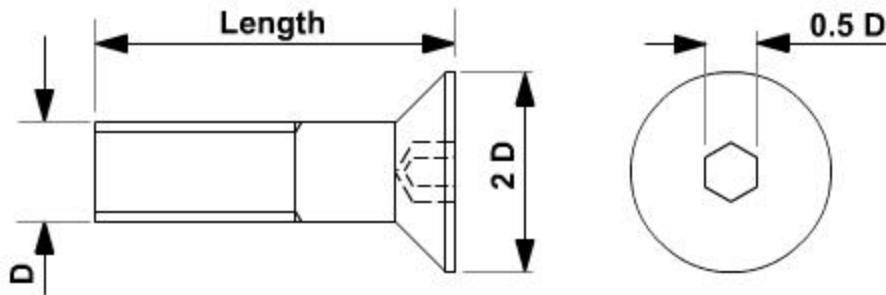

## Cap Screw

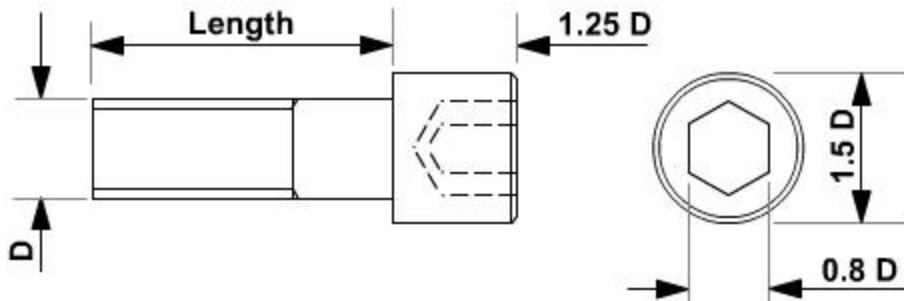

## ISO Metric Machine Screws

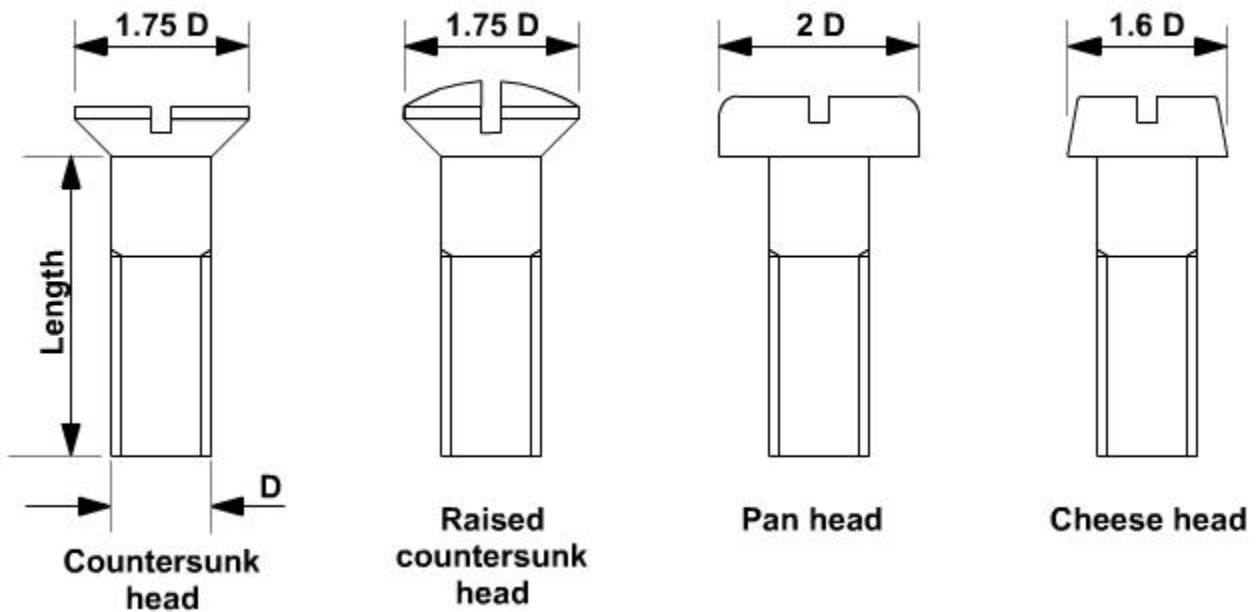

## Assorted screws, nuts and washers

The most commonly used bolts, screws and washers are shown below. They are all used to clamp product parts together. The use of nuts, bolts and screws is a **temporary fixing** method because nuts, bolts and screws can be unscrewed and the components that they were holding can be removed from their previously fixed positions.



## Screw thread

The thread on screws intended for use with wood and manufactured boards is generally deeper, i.e. the thread has a greater height than the thread on machine screws and bolts intended for use with metals.

The screw thread also has a smaller internal angle, creating a sharper thread and it also has a greater pitch.

**A wood screw cuts its own thread in wood and manufactured boards.**

The screw core fits into a pilot hole drilled to the size of the core diameter of the screw and the sharp thread on the screw cuts a thread in wood and manufactured boards as it is rotated and screwed into the timber.

## Taps and Dies

Most metals are generally too hard for self tapping screws, so a thread has to be cut using a tap in order that machine screws and bolts can be screwed into them.



Tap

Screw threads are cut in metals using tools called taps and dies.

A tap cuts an internal thread.  
A die cuts an external thread.



Die

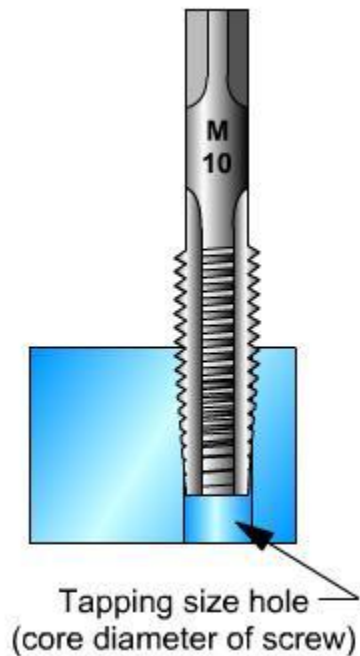
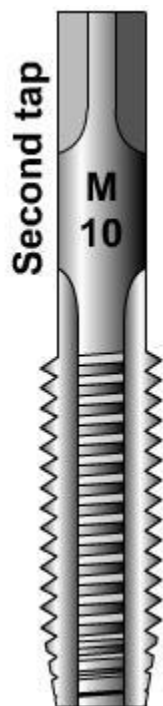

To create an internal thread, a hole is first drilled the size of the core diameter of the screw. This is called a tapping size hole. Next, the taper tap is screwed into the hole and then removed, next the second tap and then the plug tap. The taps cut a screw thread in the hole.

## Cutting an internal screw thread

Taps are held in a tap wrench. The taper tap is screwed into metal first by turning the tap wrench  $1\frac{1}{2}$  turns clockwise, then  $\frac{1}{2}$  a turn back. This process is repeated until the tap is screwed right in. The process is repeated with the second and plug tap.

A little cutting oil or grease is wiped onto the tap to help it cut and to give the screw thread a smooth finish.

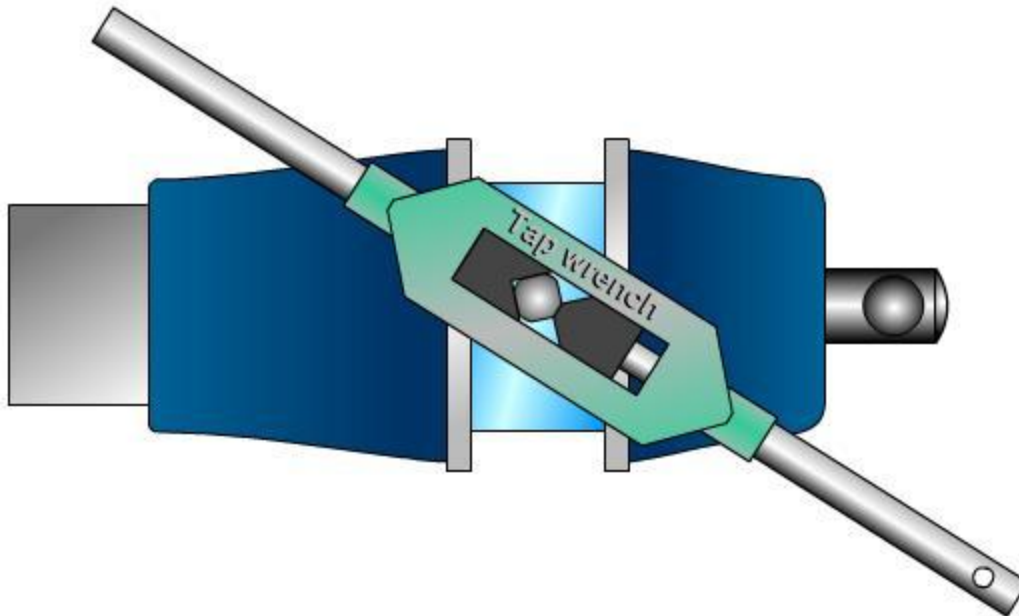

## Cutting an external thread

The usual way of cutting screw threads in schools is by using a die held in a die stock. The most commonly used dies in schools are split circular dies that are held in a die stock.

The diestock has three screws that locate in recesses and the slot in the split circular die. By adjusting the three screws, the die can be enlarged or made slightly smaller, thus cutting a slightly oversize or slightly undersized screw thread.

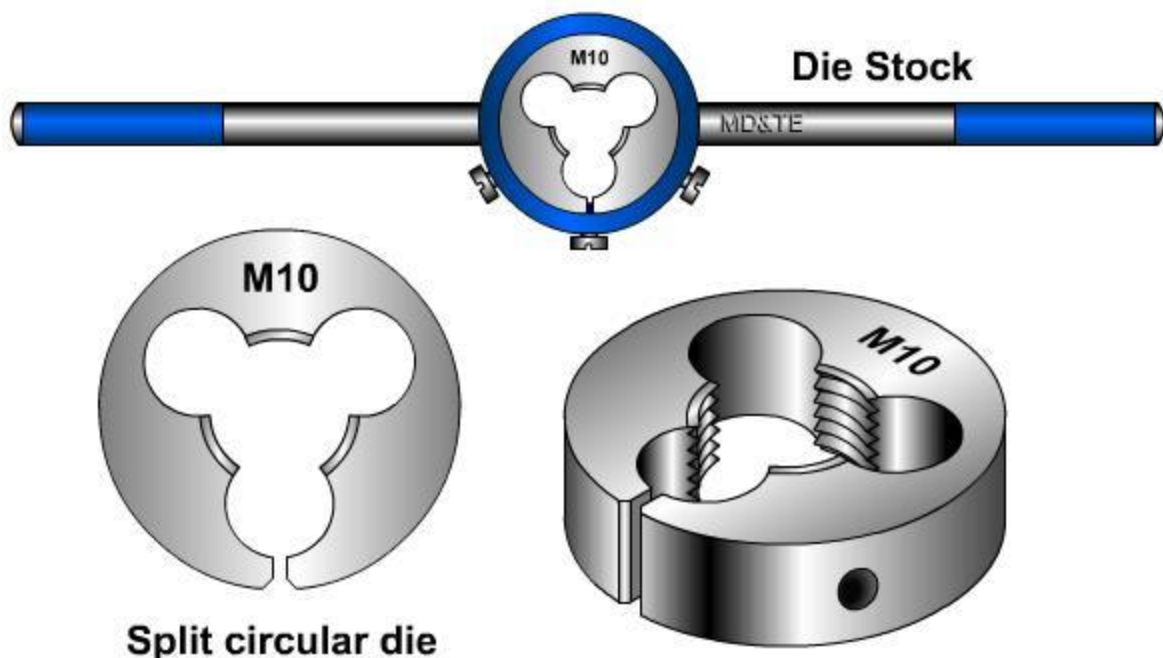

The die stock is turned over so that the bottom is facing upward. The die is located on the shaft and is then screwed onto it; turning  $1\frac{1}{2}$  turns clockwise, then  $\frac{1}{2}$  a turn back. This process is repeated until a sufficiently long thread is cut.

A little cutting oil or grease is wiped onto the die to help it cut and to give the screw thread a smooth finish.

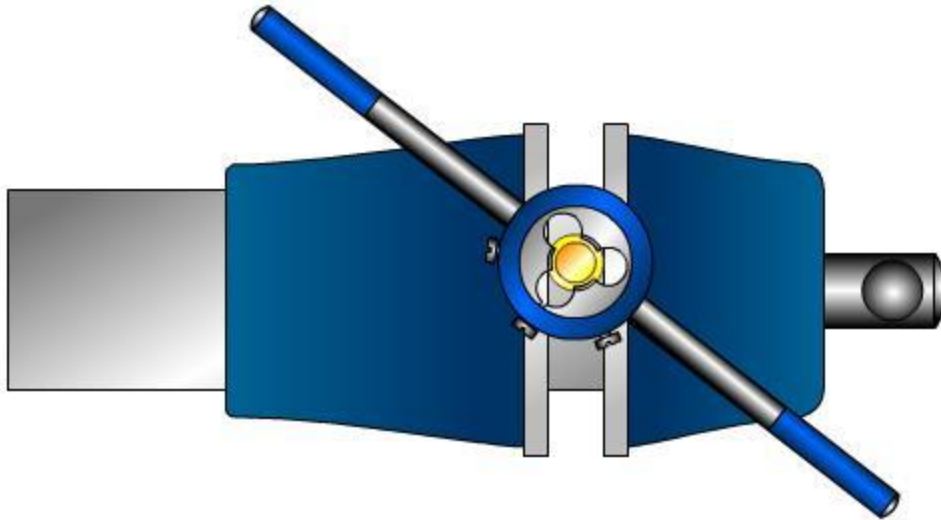

It is vitally important to keep the die and die stock square to the bar or a drunken thread will be cut.

### Die stock held square to the bar

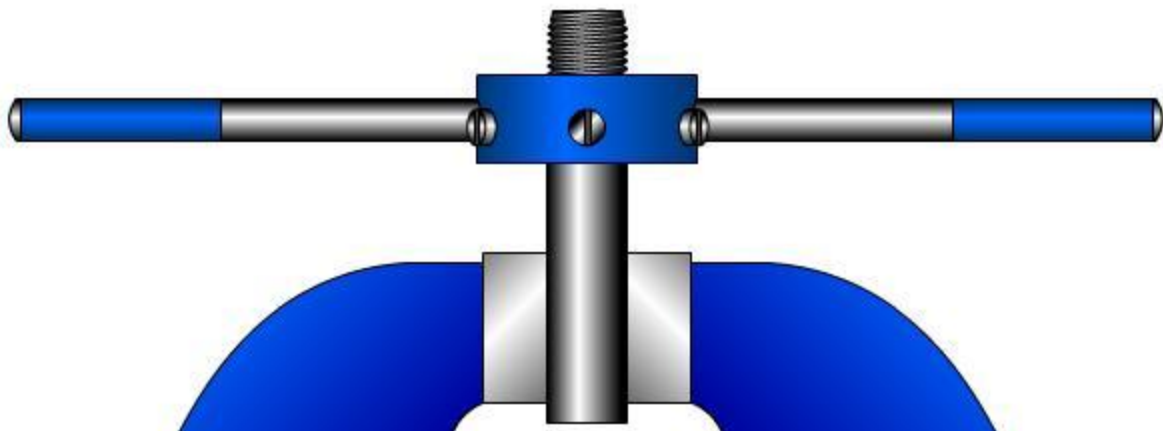

### Drunken thread

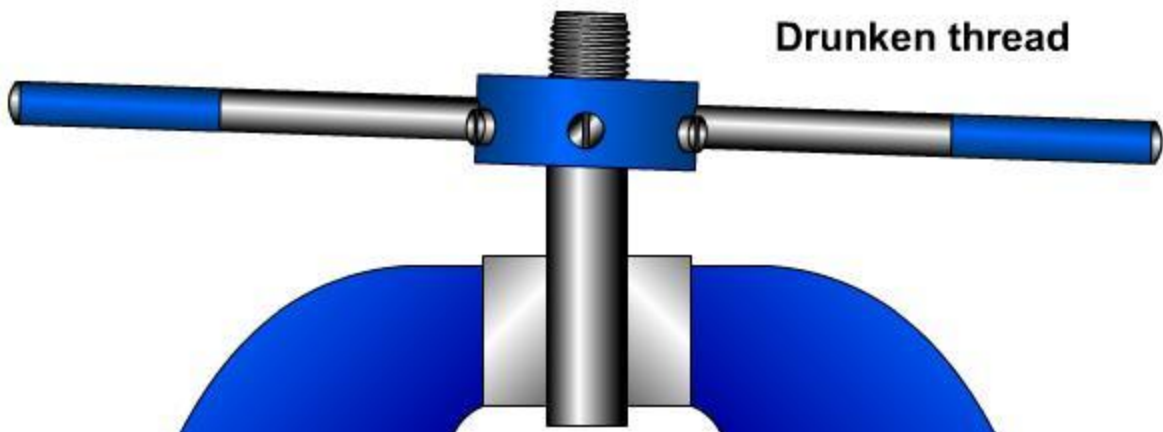

## Cutting an external thread on a lathe

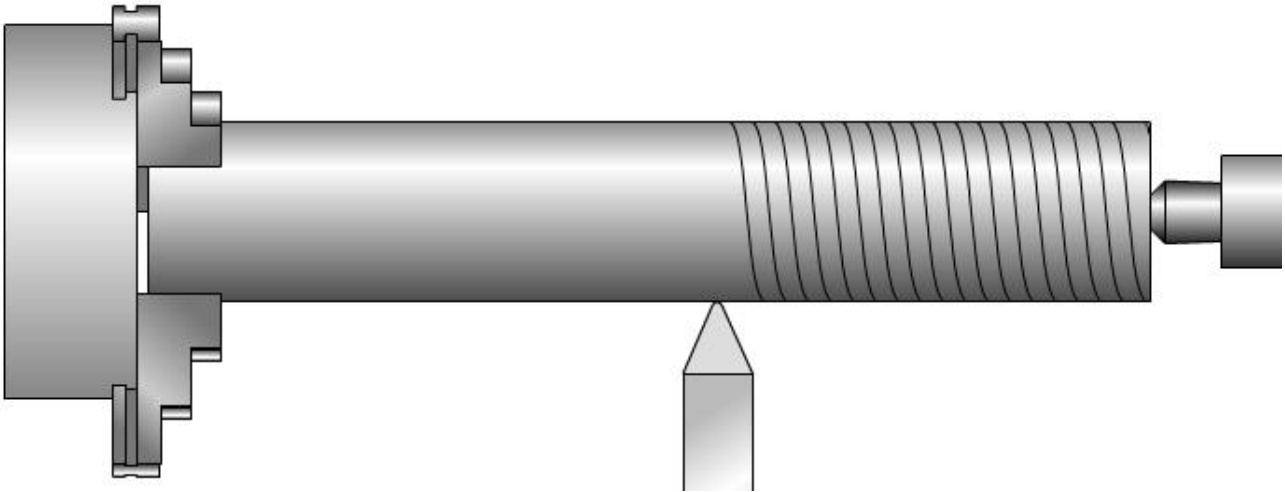

The rotation of the lathe chuck is matched with the feed of the lathe carriage to give the correct pitch for the screw thread. Several passes are made, cutting a little deeper with the lathe cutting tool each time until the correct thread profile is achieved.

The cutting tool must be shaped and positioned correctly to give the correct thread angles.

## Commonly used thread forms

### Metric Thread

This is the thread most widely used on most nuts and bolts in Europe. It is a general purpose screw thread.

Metric threads are denoted by the letter M, e.g. M8 denotes an 8mm Metric Thread.

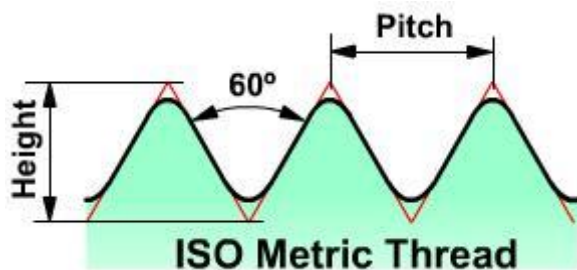

### Acme Thread

The acme thread is used on machine feed screws, particularly where a split nut will be engaged and disengaged.

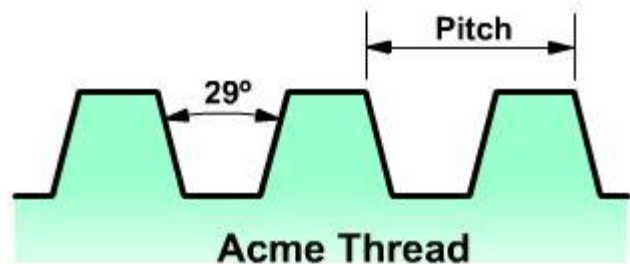

### Square Thread

A square thread is a heavy duty thread used on vices, screw jacks and for moving parts of machinery.

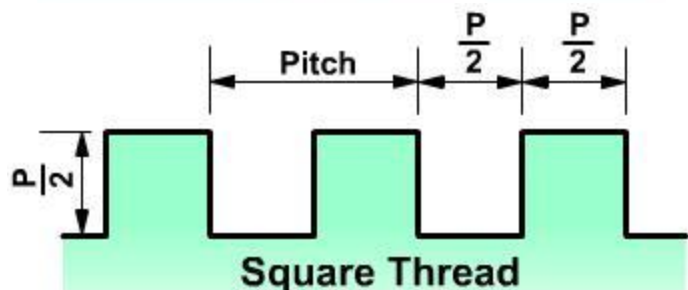

### Buttress Thread

The buttress thread is strong in one direction only. It is used on woodwork vices with a quick release mechanism. The quick release mechanism engages and disengages easily with the sloping sides of the screw.

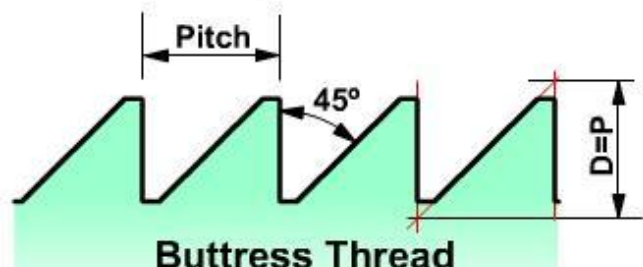

## Example of a screw used as part of clamping device



A mitre clamp is shown above. A mitre clamp is used to clamp timber and other resistant materials at right angles. The mitre clamp shown above is intended to be used with timber. It is used to hold two lengths of timber at right angles, particularly when parts of a frame are being glued and assembled.

### Analysis

The clamp consists of:

- a cast aluminium body with a spray painted finish
- two sliding clamp jaws
- four oil blacked clamp jaw pads.
- two screws with an **acme screw thread**
- a quick release mechanism for each of the two screws built into the mitre clamp body
- two knurled aluminium handles attached to the screws.

As with all clamps that utilise a screw, the screw rotates and moves through a stationary internal thread.

In the example above, the screw is rotated manually using the knurled aluminium handle. The screw pushes or pulls the sliding clamp jaw, depending on which way the screw is rotated.

The screw has an acme thread. The acme thread is used because it can bear heavy loads and is suitable for use with quick release mechanisms that utilise a split nut or other disengaging nut.

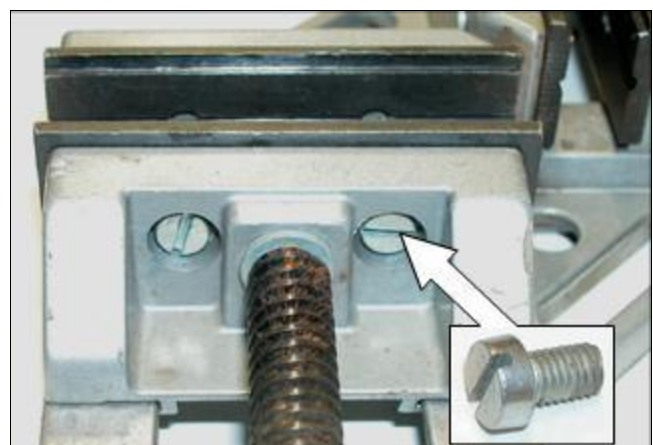

The clamp has four removable oil blacked steel jaw pads. These are held in place by slotted cheese head screws, recessed in counterbores. The cheese head screws are used to pull the clamp jaw pads firmly against the clamp jaws.

The two long screws are used to move the sliding clamp jaws. The internal screw threads in the mitre clamp body are stationary and the long screws move backwards and forwards through them. When the screws are rotated, the screws move backwards or forwards, depending on the direction of rotation and push or pull the sliding clamp jaws.



## 2. Using screws to control motion

Products are nearly always manufactured using machines, either operated by humans or computer numerically controlled (CNC). Machines are used to cut, shape, assemble and join materials. The quality of machined parts is dependent on how well the tool that is doing the cutting, shaping, assembling or joining is controlled and also how well the material that is being machined is controlled.

One common way of controlling the way that parts of a machine move is by using long screws called lead screws.

A lead screw is held in a fixed position on a machine but it can be rotated. As the lead screw is rotated, it moves the part of the machine that is attached to it.

A machine tool may have three or more lead screws moving various parts of the machine along slide ways, e.g.

- one lead screw would move a top slide forward and backward along the Y axis
- another lead screw would move a cross slide left and right along the X axis
- a third screw would move the sliding table assembly along a vertical slide way up and down along the Z axis.

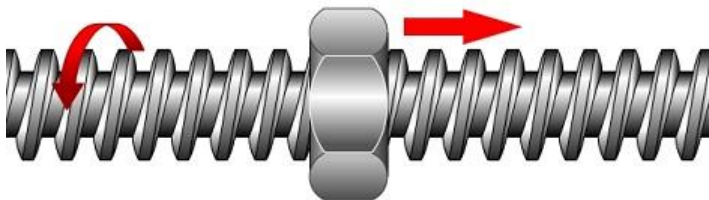
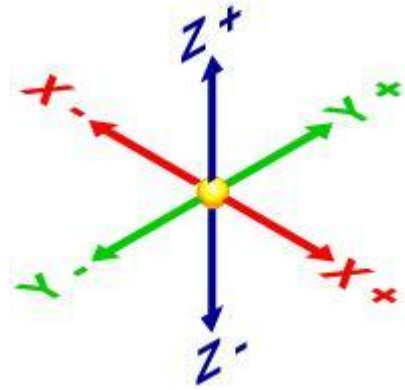

The screw rotates, the nut does not rotate, the nut moves along the screw.

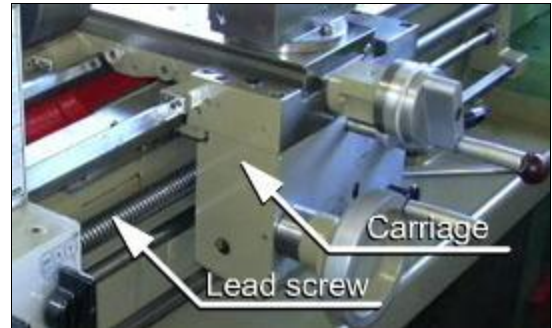

The diagram above left illustrates a lead screw that is made to rotate but the nut is prevented from rotating. When the lead screw rotates and the nut is prevented from rotating, the nut travels along the lead screw. When the nut is attached to a carriage or machine table, the carriage or machine table is moved when the screw is rotated. This is the principle used to move the milling machine table illustrated below and the lathe carriage illustrated above.

Hand wheels are used to turn the lead screws that control the movement and position of the top slide and cross slide on manually operated milling machines.

On computer numerically controlled (CNC) milling machines, the hand wheels are replaced by servo motors.

The servo motors are connected to lead screws that move the machine table through the X, Y and Z axes

### Vertical Milling Machine

On manually operated machines, handwheels connected to leadscrews are used to move the machine table along the X, Y and Z axes.

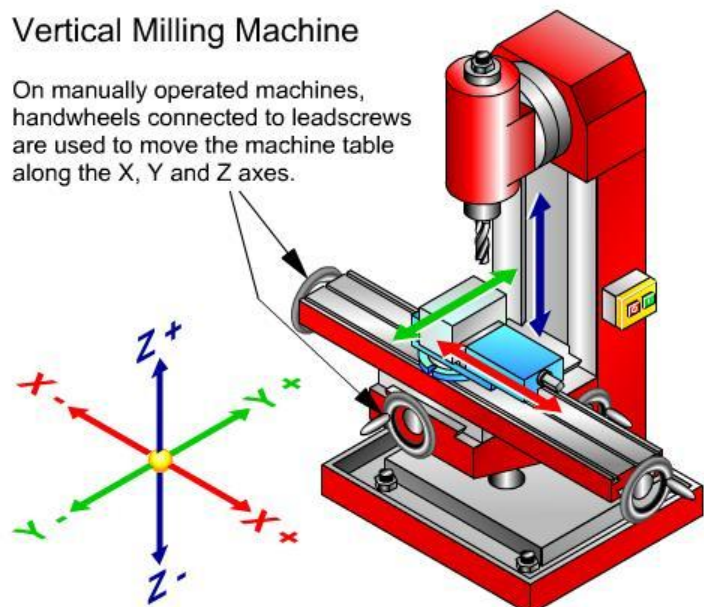

# Backlash

Backlash is the axial movement between a screw and nut. The movement is caused by the gap between the screw threads of the screw and nut.

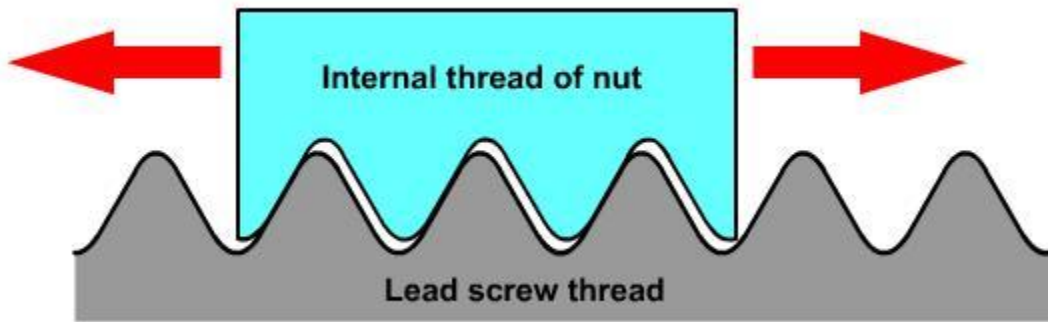

Backlash may not be important when the screw is used for clamping but when used for controlling the movement of machine parts, backlash is a very important consideration. This is because any backlash between the screw and the part of the machine that the screw is controlling will lead to inconsistent movements of that part.

## Method 1

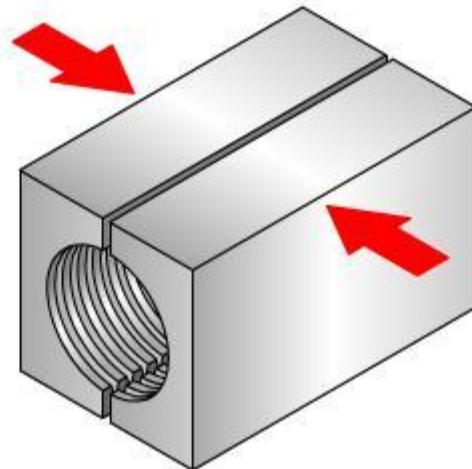
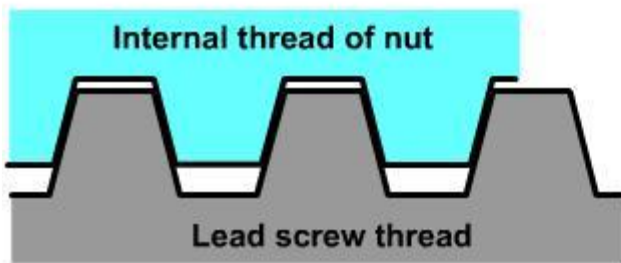

One way that backlash may be eliminated is by using a split nut that can be closed tightly around a lead screw. The "V" form of the screw thread closes gaps between the threads of the screw and nut. Method 1 above illustrates how a split nut is used to reduce backlash on a lathe lead screw. This type of split nut is also used to engage and disengage the lead screw on a lathe.

The diagram below illustrates one type of anti backlash nut. This design consists of two nuts with a spring between them that forces the nuts apart and against opposite faces of the lead screw thread. This prevents movement forwards and backwards.

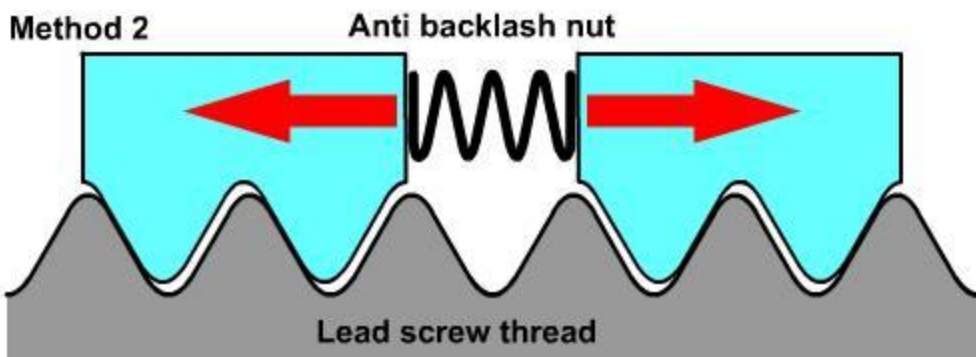

The diagram below illustrates another type of anti backlash nut. This design consists of two nuts that are bolted together with a special spacer between them. The bolt holds the two nuts against the opposite flanks of the lead screw and the spacer prevents the two nuts from being over tightened and seizing on the screw.

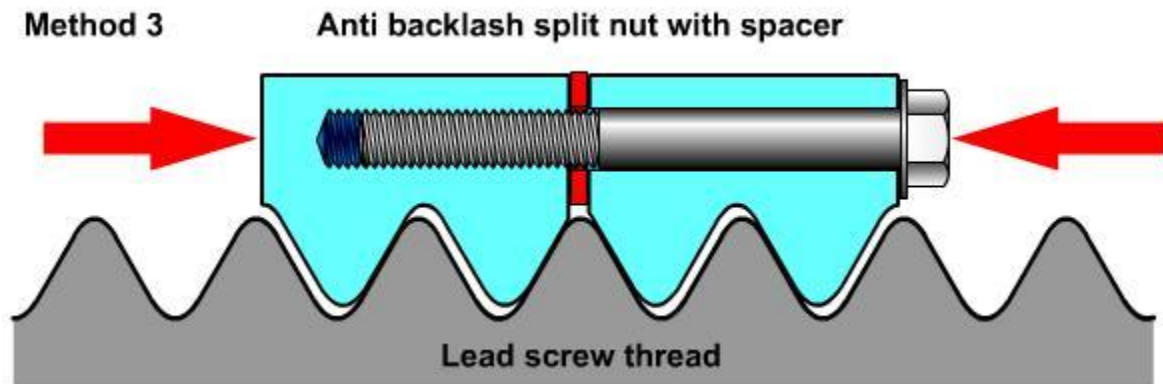

## Ball Screws

Ball screws are actuators. Actuators convert an input into motion.

Ball screws convert rotary motion into linear motion and vice versa. The design of the ball screw eliminates backlash and minimises friction between the screw and nut. Instead of interlocking internal and external screw threads, as in other types of machine screws, the ball screws trap ball bearings in the semi circular helical grooves between the screw and nut.

The screw part of the system is a ground shaft with a semi circular helical groove cut into it. The nut part of the system consists of a tubular shaft with a circular helical groove cut into the inside of it. There is a channel in the nut that connects the end of the groove to the start of the groove, making the nut a closed circulation system. These grooves and the channel are called raceways. The ball bearings roll inside the raceways.

The finely ground ball bearings create very little friction between the balls, the screw shaft and the ball assembly unit, i.e. the nut. The ball assembly unit moves freely along the shaft.

Ball screws are used wherever rotary motion has to be converted into linear motion with a high degree of precision. They are used in computer numerically controlled (CNC) machines, in some power steering systems and other precision applications.

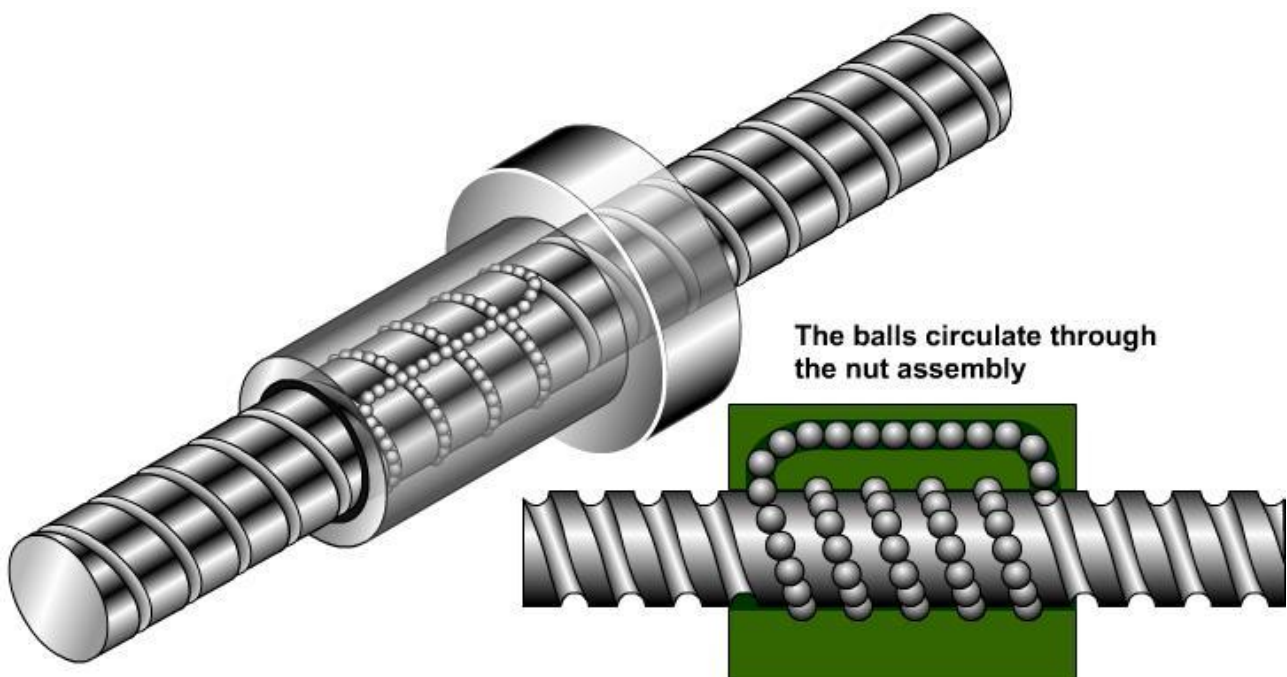

## Roller screws

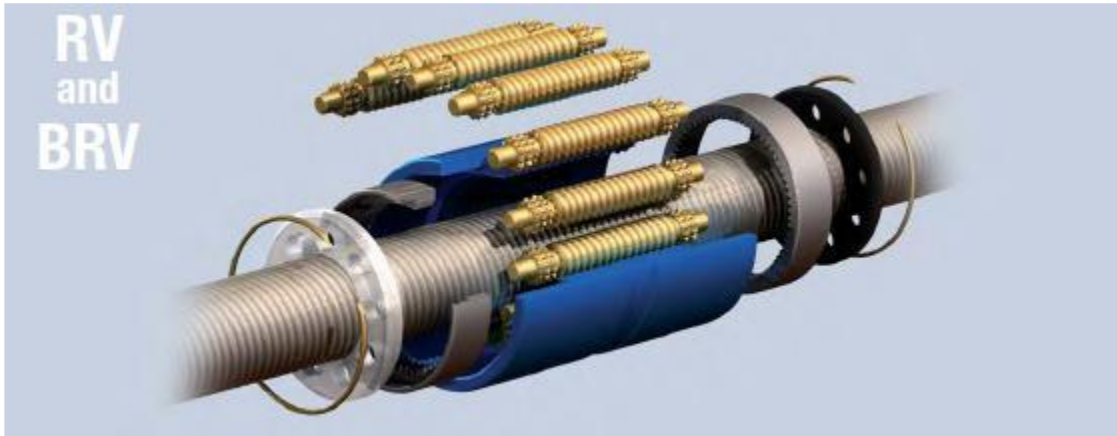

Image courtesy of ROLLVIS SA [www.rollvis.com](http://www.rollvis.com)

Roller screws have three main parts, the screw, the nut and the rollers that transmit motion and force from the screw to the nut or from the nut to the screw. Roller screws convert:

- rotary motion and force into linear motion and force
- linear motion and force into rotary motion and force.

When the screw is rotated, the nut travels along the screw.  
When the nut is rotated, the screw travels through the nut.

Rollers are used between the screw and nut because they create less friction than a nut and screw that are in direct contact. Rollers can support very heavy loads because of the large number of points of contact. The rollers have a gear at each end which mesh with ring gears. The ring gear keeps the rollers aligned along the screw correctly.

The nut assembly may consist of a single nut, a split nut or a double nut. The use of a single nut results in a small amount of backlash between the nut and the screw. Backlash is the small amount of forward and backward longitudinal or axial movement between the screw and a nut caused by the spaces between the screw threads.

Split nuts have a spacer between the two halves of the nut. The two halves are clamped together by screws to eliminate backlash and so increase accuracy.

Roller screws are also called **planetary roller screws** and **satellite roller screws** because rollers orbit the screw.

Roller screws are classified as **actuators** because they transmit motion and force and convert rotary motion into linear motion and vice versa.

The satellite roller screws catalogue by ROLLVIS SA has detailed descriptions and clear illustrations of roller screws. To view the ROLLVIS SA Satellite Roller catalogue please go to:  
<http://www.rollvis.com/EN/resources/Rollvis-2013-EN.pdf>